

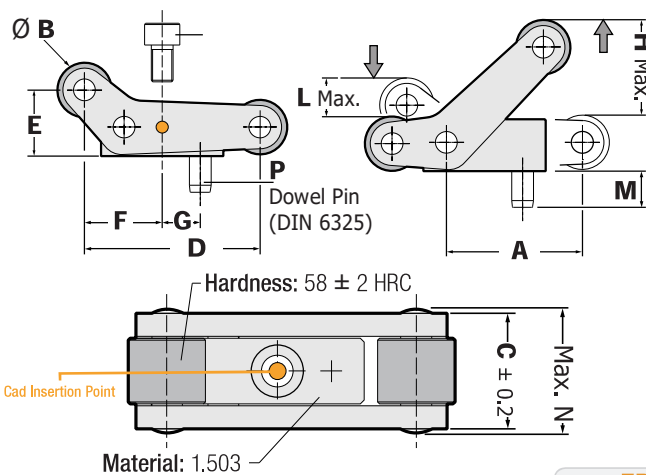

Ejector Plate Accelerator

Code: EP

This item allows increased movement of a second ejector plate within a normal ejector stroke. Simple mechanical double ejection system. Minimum space required for installation. Avoids complex systems like others currently available in the market. In small and medium moulds with standard ejectors, 1 piece is sufficient. In more larger moulds and systematic moulds according to their configurations, dual Ejector Plate Accelerator can be used. In a symmetric manner, generally 4 pieces.



Code: EP

Order	A	B	C	D	E	F	G
EP.200813	20	8	13.2	25.8	9.4	11.4	6
EP.251016	25	10	16	32.3	11.8	14.3	7
EP.371522	37.5	15	22	48.5	17.7	21.5	10.5
EP.502030	50	20	30	64.6	23.6	28.6	14

H Max.	L Max.	M	N	Ø P	T	Max. Force
11.6	4.4	5	15	2.5 x10	M3 x12	125 Kg.
15	5.7	6	18.5	3 x12	M4 x16	250 Kg.
23.5	9.1	8	25	4 x16	M6 x25	350 Kg.
32	12.5	10	34	5 x20	M8 x30	800 Kg.

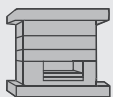
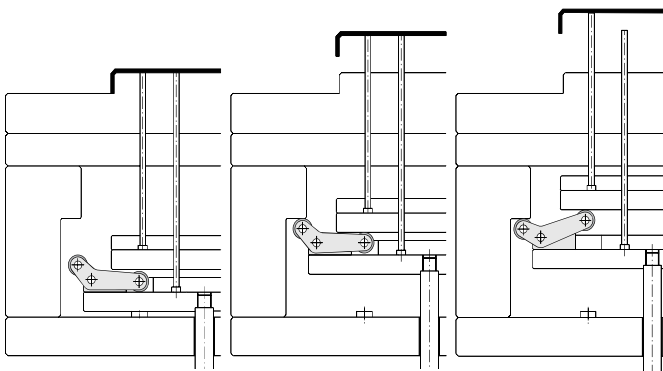

NOTE: It is recommended two piece to be used reciprocally in ejector system in mould applications.



Superior Double Ejector

Code: DX

The rear plates stop and the upper plates continue for the full ejection stroke. Thanks to the assembly of the units away from the center of mold but within the ejector frame the space required for installation is drastically reduced leaving more space for other mechanisms. Also works as the ejector guide pins and bushes, having the possibility of eliminating the need to install extra items. Maximum working temperature 150°C.

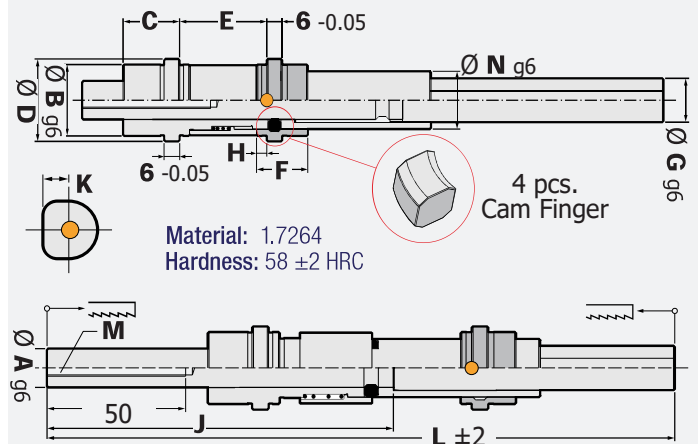

Code: DX

Order	A	B	C	D	E	F	G	H
DX.142622	14	26	22	30	34	20	16	4
DX.163027	16	30	27	34	44	23	18	6

J	K	L	M	N	L1	L2
125	7.2	243	M6	21	42	48
152	8	314	M8	24	54	80

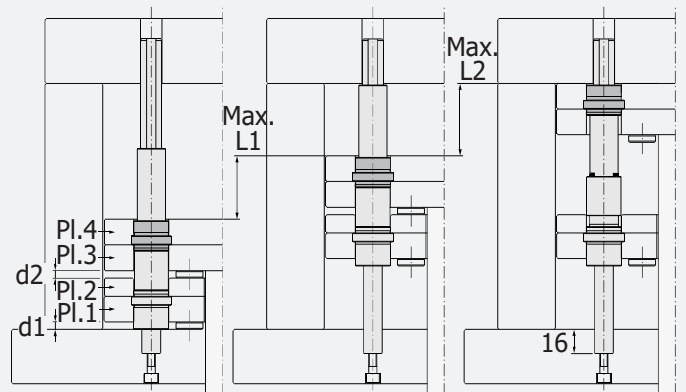

Standard Ejector Plate Combination

Size mm	DX.142622				Size mm	DX.163027								
	1	2	3	4		1	2	3	4	5	6	7	8	9
d1	5	5	5	5	d1	5	5	5	5	0	0	0	0	0
Pl.1	17	17	17	17	Pl.1	22	22	22	22	27	27	27	27	27
Pl.2	9	12	12	12	Pl.2	12	12	17	17	17	17	17	22	22
d2	13	10	5	5	d2	5	5	5	5	5	5	10	0	0
Pl.3	12	12	17	17	Pl.3	27	27	22	22	22	22	17	22	22
Pl.4	9	9	9	12	Pl.4	17	22	12	17	12	17	12	12	17