

NEW



Angled Guide Pillar

Code: **G161**

- Compatible Guide Bush: "G61"
- No reworking necessary before mounting.

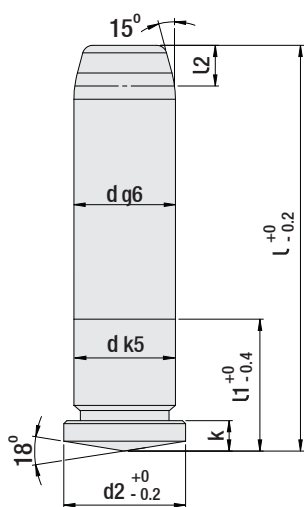

Mounting Example

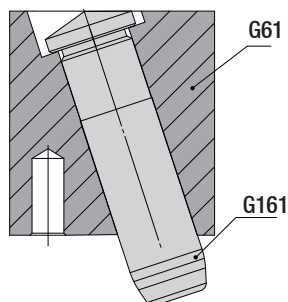

Order: **G161. d x l**

Material: $\varnothing 20 = 1.7131$
> $\varnothing 20 = 1.1213 (Cf53)$
Hardness: 58 - 62 HRC

Page
50

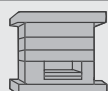

Injection
Moulds

Code: **G161**

d	l	l1	l2	d2	k
12	40	34	4	16	6
	60				
	80				
	100				
	120				
	140				
14	60	34	4	18	8
	80				
	100				
	120				
	140				
	160				
16	40	43	7	20	8
	60				
	80				
	100				
	120				
	140				
20	60	43	7	24	8
	80				
	100				
	120				
	140				
	160				
25	80	52	7	28	15
	100				
	120				
	140				
	160				
	180				
30	100	60	7	36	15
	120				
	140				
	160				
	180				
	200				
30	200	60	7	36	15
	220				
	240				
	260				
	280				
	300				

NEW



Angled Guide Bush (Core pillar holder)

Code: **G61**

This unit eliminates angular perforation requirement. To insert this unit, only a hole is perforated at the front of the mould.

Angled guide bush can be used with G161, G14 or G17 guide pillar.

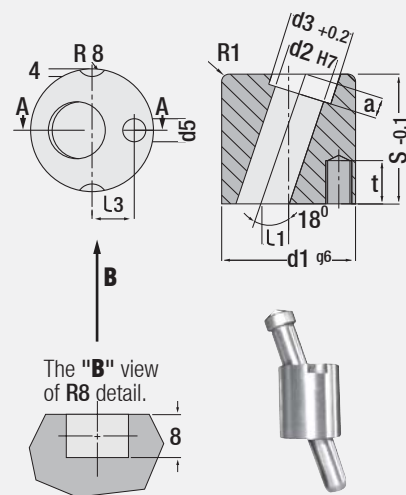

Angled Guide Bush

Code: **G61**

d2 H7	s -0.1	d1 g6	a	d3 +0.2	L1 ±0.15	L3	d5	t
12	36	32	6	17	7	10	M6	11
14	36	36	8	19	7	12	M8	16
16	46	40	8	21	8.5	13.5	M8	16
20	46	45	8	25	8.5	15	M8	16
25	56	50	15	29	10	16	M8	16
30	66	63	15	37	12	21	M10	20



Order: **G61. d2**

Material: 1.7131 (16MnCr5)
Hardness: 58 - 62 HRC