

Conical Head Punches - Stepped DIN 9861 Form C

Code: **HKZ**

According to DIN 9861 norm, there is limitation for body and cutting diameter. In this norm, while body diameter for conical head stepped punch is max. 3 mm, cutting diameter can be max. 2.95 mm.

Material: 1.3343 (M2) Hardness: 62 - 64 HRC

d1	l	d3	d2	r			
0.8	71	2 mm	3 mm	0.4			
	80						
1.0	71						
	80						
1.2	71				2.5 mm	3 mm	0.4
	80						
1.5	71						
	80						
1.6	71						
	80						
1.8	71						
	80						
1.0	71	3 mm	4.5 mm	0.6			
	80						
1.5	71						
	80						
1.8	71						
	80						
2.2	71				3 mm	4.5 mm	0.6
	80						
2.3	71						
	80						
2.6	71						
	80						
2.8	71						
	80						



Order: **HKZ. d3 x d1 x l**

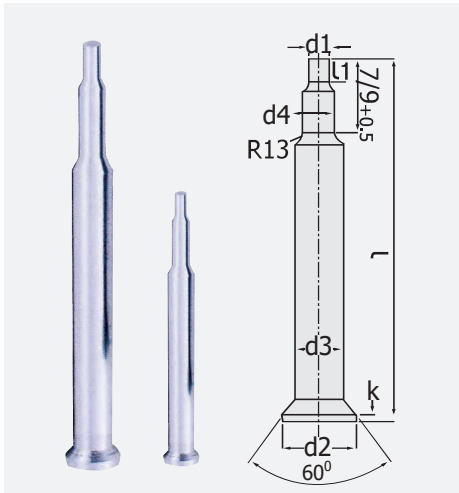
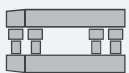

Conical Head Punches - Stepped DIN 9861 Form E

Code: **H2K**

As per request, our punch production is available in the desired material and dimensions and also in shapes. It is preferred for thin work pieces and light duty works.

Material: 1.3343 (M2) Hardness: 62 - 64 HRC

d1	d4	d3	d2	l	L1		
1.0	1.4	Ø 3.0	4.5 mm	71	2 mm		
1.2	1.6						
1.5	1.8						
1.7	2.1						
2.2	2.6						
2.5	2.8						
1.6	2.2		Ø 4.0	5.5 mm		71	2.5 mm
1.8	2.3						
2.3	2.8						
2.6	3.0						
3.0	3.5						
3.2	3.7						
2.4	3.0	Ø 5.0	6.5 mm	71	3 mm		
2.8	3.5						
3.2	4.0						
3.6	4.2						
4.2	4.6						
4.5	4.8						
2.5	3.2	Ø 6.0	8 mm	71		3 mm	
3.0	3.8						
3.5	4.2						
4.0	4.8						
4.5	5.3						
5.0	5.5						
5.5	5.8						



Order:
H2K. d1 x d4 x d3 x l x L1



Conical Head Punch, Slot - Shaped Slot - Form DA (Forged head)

Code: **HFK**

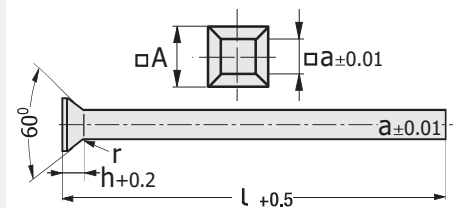

a	l	A	h
1.0	71	1.8	1.2
2.0		3.0	1.4
3.0		4.5	1.8
4.0		5.5	1.8
5.0		6.5	1.8
6.0		8.0	2.2
a	l	A	h
7.0	71	9.0	2.8
8.0		10.0	
9.0		11.0	
10.0		12.0	
12.0		14.0	



Order: **HFK. a x l**

Conical Head Punches - Shaped (Forged head)

Code: **HFY**

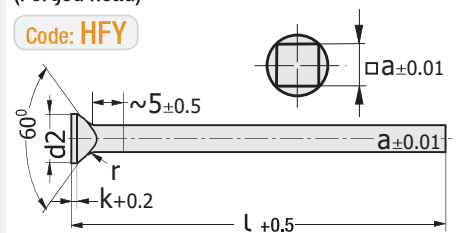

a	l	d2	k
1.0	71	1.8	0.5
2.0		3.0	
3.0		4.5	
4.0		6.0	
5.0		7.5	
6.0		9.0	
a	l	d2	k
7.0	71	10.5	1.0
8.0		12.0	
9.0		13.5	
10.0		15.0	
12.0		18.0	

Excluding product types in tables, our production such as headless and different slot types, also punches as per request are available.



Order: **HFY. a x l**