

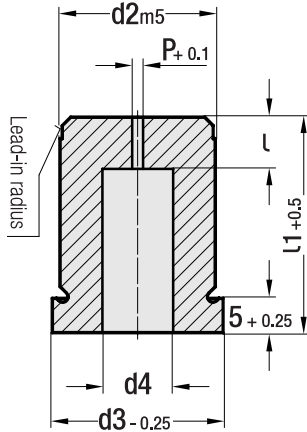

Matrix with Locking Device
ISO 8977

Code: MF..



With starting holes for "wire-edm".

Specification: Diameter d1, d2 and lead-in radius ground.

Material: 1.3343 (M2)

Hardness: 60 - 62 HRC

* d1: Size on corners "key flat" (F size) should be specified as per request.

d2	d3	d4	P	l	L1
5	8	2.8	0.8	2	16
6	9	3.5	1	3	20
8	11	4.0	1	4	22
10	13	5.8	1.2	4-8	22
13	16	8.0	1.2	5-8	25
16	19	9.5	1.5	8-12	28
20	23	12	1.5	8-12	30
22	25	15	1.5	8-12	32
25	28	17.3	1.5	8-12	35
32	35	20.7	1.5	8-12	as per request
40	43	27.7	1.5	8-12	as per request
50	53	37	1.5	8-12	as per request

l length: with 2 alternatives

L1 length: to be selected as per request.

Order: MF(type).

d2 x l x L1 x shape (P/W/R/G)

Page

190

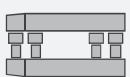

Dies

Locking Device

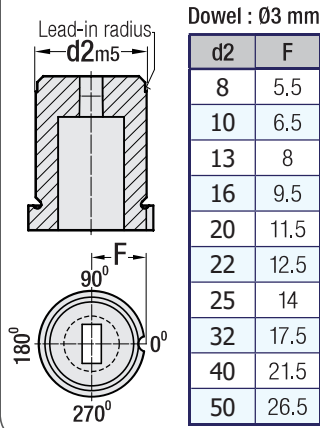

Dowel : Ø3 mm

d2	F
8	5.5
10	6.5
13	8
16	9.5
20	11.5
22	12.5
25	14
32	17.5
40	21.5
50	26.5

Locking Device

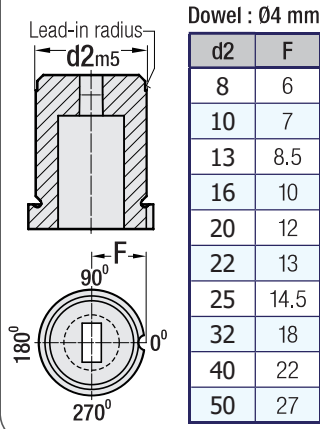

Dowel : Ø4 mm

d2	F
8	6
10	7
13	8.5
16	10
20	12
22	13
25	14.5
32	18
40	22
50	27

Locking Device

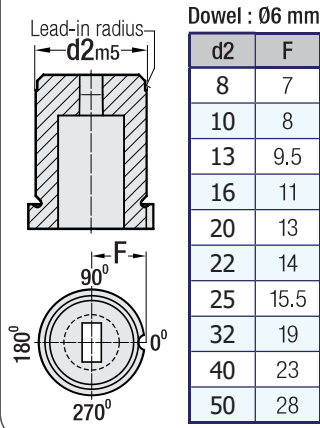

Dowel : Ø6 mm

d2	F
8	7
10	8
13	9.5
16	11
20	13
22	14
25	15.5
32	19
40	23
50	28

Locking Device

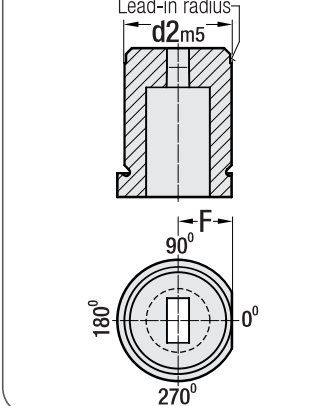

Shapes

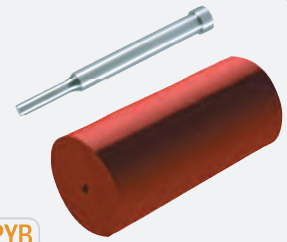
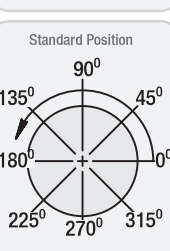
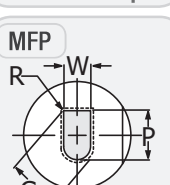
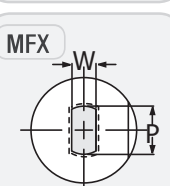
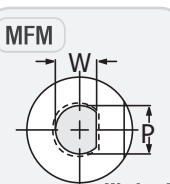
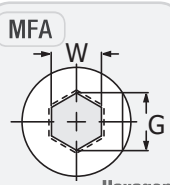
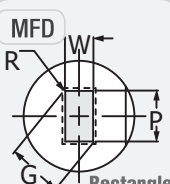
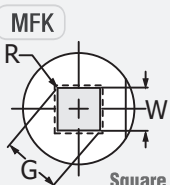
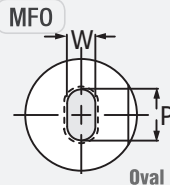
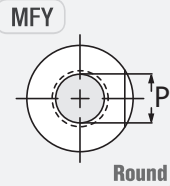

NEW

Code: PYB

Polyurethane Punch Stripper
Overspread on punch (shock absorber)

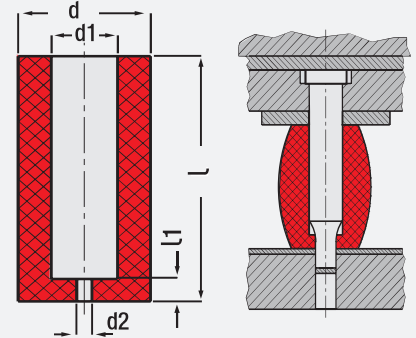

In dies that polyurethane punch stripper is used, there is no need to dismantle stripper plate to make repair whetting and modification on die components, there is not any effect on precise parts, it is excellent for all painted / anodized, plastic plated and polished parts. It is compatible to use with oil and grease.

It is overspread on punch. Placement is done according to the stripper hardness. There is no need for extra holder. Stepped-punch hole will be opened at the first stroke of press on stripper edge.

Especially, in large dies requiring very wide stripper plate, this product is very compatible.

Code: PYB

Order	d1 Ø	d Ø	d2 Ø	l1 mm	l mm	Punch Length
PYB.445	4.0	17	1.6	5.0	45	56 / 63
PYB.655	6.0	19				
PYB.855	8.0	21	3.0	5.0	55	63 71 80 90
PYB.1055	10	23				
PYB.1355	13	26	5.0	55	100	
PYB.1655	16	30				
PYB.2055	20	38	5.0	55	100	
PYB.2555	25	50				

d2: (1.6 - 3.0 mm) (d1) while opening hole diameter / drilling, polyurethane (punch) bush should be applied and drilled in pressed (S max) position. Spring load is obtained while extending outwards.

In S. max flexion, load coefficient data daN / Kg.

d mm	17	19	21	23	26	30	38	50
S daN	60	65	70	90	110	140	210	370
3 mm daN	daN	daN	daN	daN	daN	daN	daN	daN
S daN	115	120	130	160	190	230	360	650
6 mm daN	daN	daN	daN	daN	daN	daN	daN	daN
S daN	-	180	210	240	300	370	550	1020
9 mm daN	daN	daN	daN	daN	daN	daN	daN	daN

S max: Load coefficient daN = Kg. / (10 newton), while polyurethane bush S max in pressed, load data is advisory.