

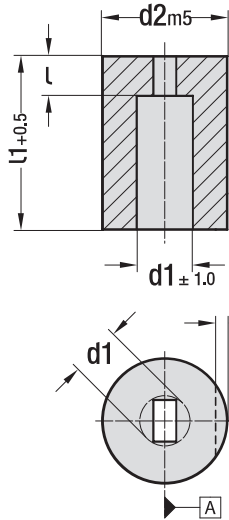

Matrix - Straight
ISO 8977 / Shape C

Code: **MK..**



With starting holes for "wire-edm".

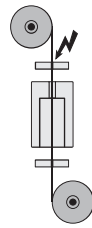

Shapes

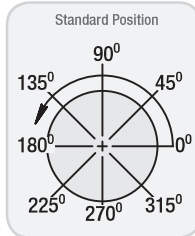
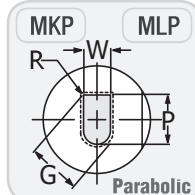
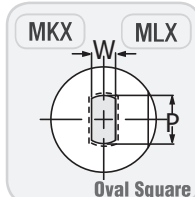
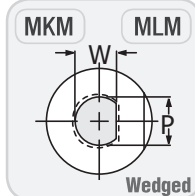
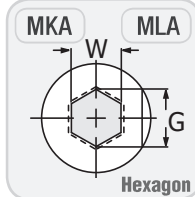
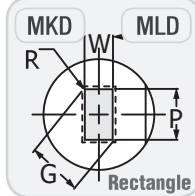
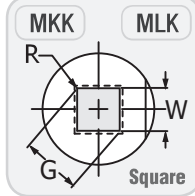
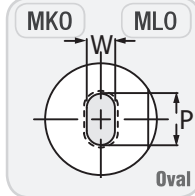
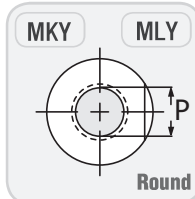

Matrix - Headed
ISO 8977 / Shape D

Code: **ML..**

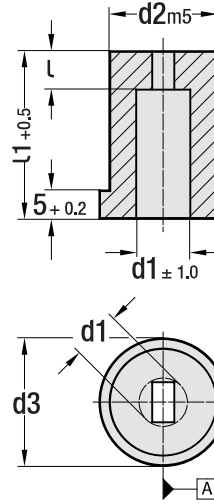

With starting holes for "wire-edm".

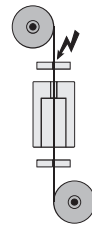

Specification: Diameter d1, d2 and lead-in radius ground.

Material: 1.3343 (M2) **Hardness:** 60 - 62 HRC

* d1: Size on corners "key flat" (F size) should be specified as per request.

Types: **MKY - MKO - MKK - MKD - MKA - MKM - MKX - MKP**

Order: **MK**(type). d1 x d2 x l x l1 x shape (P/W/R/G)

d1 = shape	d2	k	l	l1
1.8 ~ 3.2	8	1	3	16
2 ~ 5	10	1	3	19
3 ~ 7	13	1.5	3	22
5 ~ 8	16	1.5	5	25
7 ~ 11	20	1.5	5	28
11 ~ 16	25	2.5	5	32
16 ~ 19	32	2.5	7	Selection as per request
19 ~ 28	40	2.5	7	

Specification: Diameter d1, d2 and lead-in radius ground.

Material: 1.3343 (M2) **Hardness:** 60 - 62 HRC

* d1: Size on corners "key flat" (F size) should be specified as per request.

Types: **MLY - MLO - MLK - MLD - MLA - MLM - MLX - MLP**

Order: **ML**(type). d1 x d2 x l x l1 x shape (P/W/R/G)

d1 = shape	d2	d3	k	l	l1
1.8 ~ 3.2	8	11	1	3	16
2 ~ 5	10	13	1	3	19
3 ~ 7	13	16	1.5	3	22
5 ~ 8	16	19	1.5	5	25
7 ~ 11	20	23	1.5	5	28
11 ~ 16	25	28	2.5	5	32
16 ~ 19	32	35	2.5	7	Selection as per request
19 ~ 28	40	43	2.5	7	

Positioning for "key flat" matrixes:

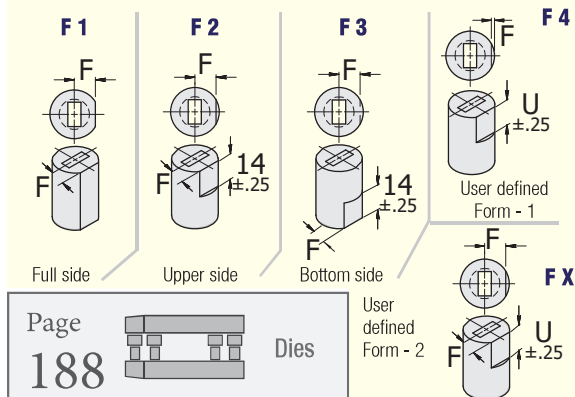

Information for positioning:

Key flat matrixes: "F" size used for "F1 - F2 - F3" has been specified in drawings on the left. "FX" size is defined by the user and while ordering, "key flat" dimension "F" and "U" should be specified.

Body Diameter	"F" +0.2	Body Diameter	"F" +0.2	Body Diameter	"F" +0.2
10	4.0	32	14	63	29.5
13	5.5	38	17	71	33.5
16	7.0	40	18	76	35.5
20	8.5	45	20.5	85	40
22	9.5	50	23	90	42.5
25	11	56	26	100	47.5

