

Important Note:
Cumsa removed this
product from sales (RP).

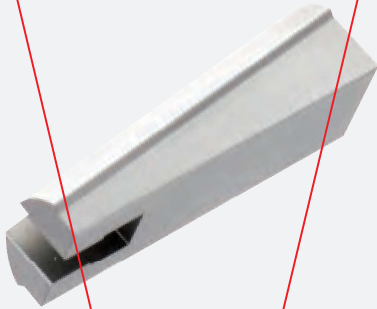

Lifter Replacement

Code: RP

They are for adjustments and levelling and used with "PS" standard lifters. The length of "RP" is set as per request.

Material: 1.2344 Hardness: 52 ± 2 HRC Patented System

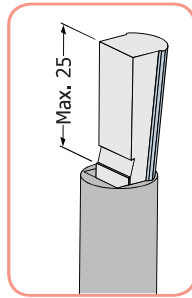
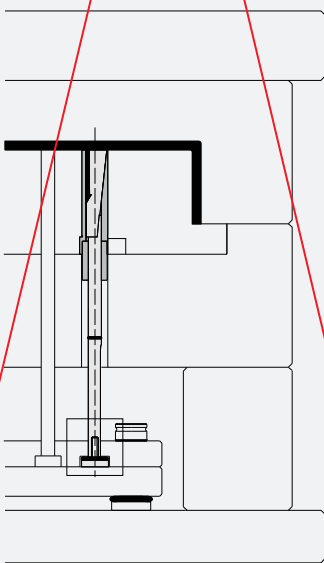
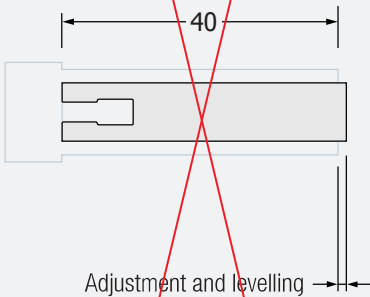

Important
Max. Operation Length

3D file can be
downloaded from
www.cumsa.com



Standard Lifter

Code: PS

Compact unit for the release of small undercuts. The unit is completely pre adjusted and easy to install. The space required for installation is reduced due to the vertical movement perpendicular to the ejector plates. Minimum space required for installation, only needs the space of an ejector. Mechanical solution. No milling, grinding or hardening other than the machining of detail needed.

Material: INOX 1.4034 Hardness: 48 ± 2 HRC Patented System

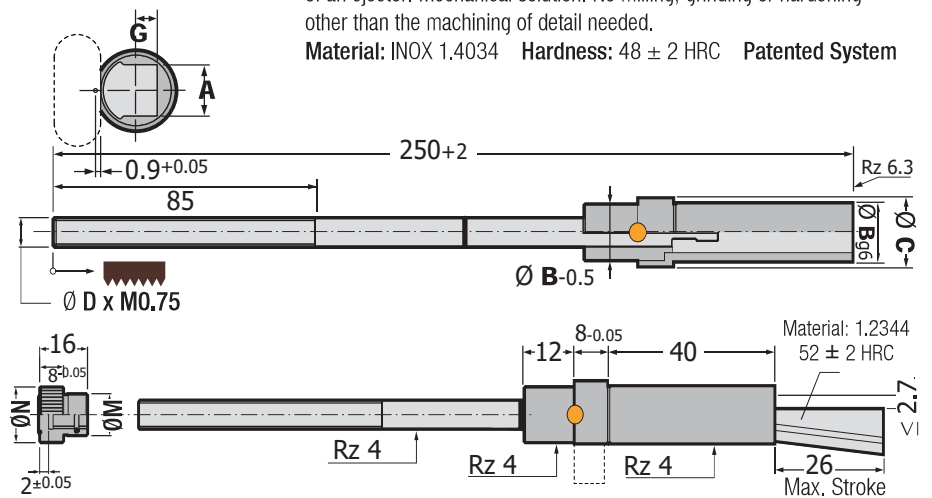

| Order | A | B | C | D | G | M | N | R |
|-----------|------|----|----|---|-----|----|----|------|
| PS.062250 | 6.2 | 10 | 12 | 6 | 3.4 | 12 | 16 | 1.25 |
| PS.082250 | 8.2 | 12 | 14 | 6 | 4 | 12 | 16 | 1.25 |
| PS.102250 | 10.2 | 14 | 16 | 8 | 4.2 | 14 | 18 | 2 |
| PS.122250 | 12.2 | 16 | 18 | 8 | 4.2 | 14 | 18 | 2 |

