



Modular Retainer

Code: **RM**

Useful for moulds that require delayed opening of parting line. Resistance can be increased by adding clips. No pocket machining required as needed with other similar products on the market. Minimum space required for installation. Reduces costs compared to conventional mechanisms. 4 pieces can be used on same surface max. The system should be distributed to different areas if the more use is needed.

Material: 1.8159 Hardness: 45±3 HRC
Max. working temperature: 150°.

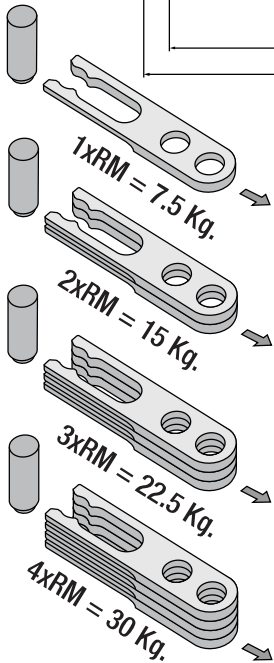
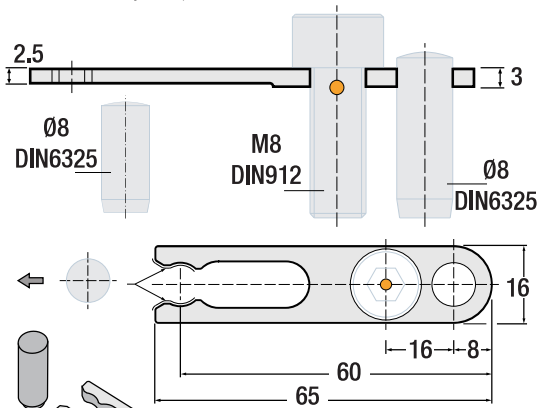

IMPORTANT!
The values displayed on the image are approximate values and they are used with 1-2-3-4 groups. Modular Retainer groups should be created in different regions / directions of the mould for more loadings.

Fasteners:
Screw and pin should be procured separately.

Order:
RM.651608
(1 pcs.)

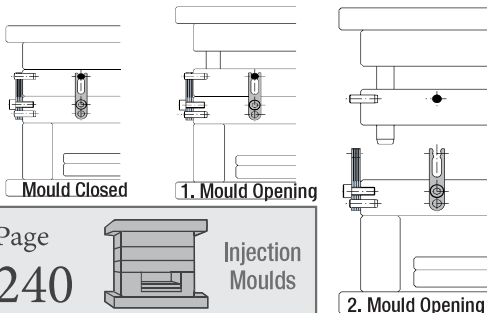

Stroke Limiter

Code: **SL**

Stroke mechanical limiter for PR - Plate Retainer. When PR coded product is used dual opening systems with stripper limit stroke of bearing plate which is opened first in 1st group. Possibility to reduce the max. opening - 60mm. Then 2nd group's opening is engaged.

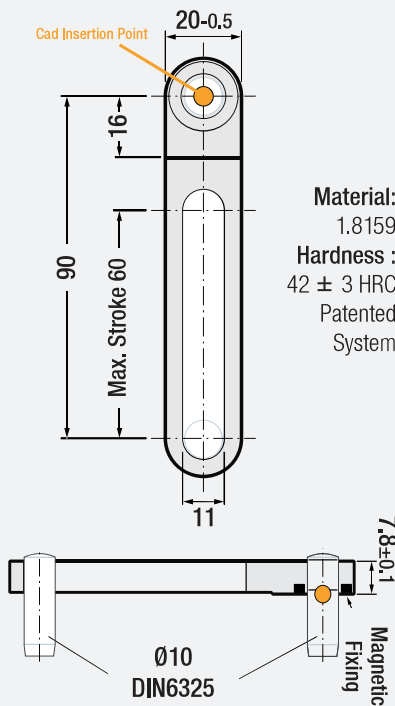

Material:
1.8159
Hardness :
42 ± 3 HRC
Patented
System

Order:
SL.602008



Plate Retainer

Code: **PR**

PR - Guarantees that the second opening stays closed until the first is completely open. 50 Kg. opening load required per unit (Minimum of 2 parts required). Possibility to change inner spring from the parting line. Also protects mould affecting from vibrations and impacts by reducing speed tension and absorbing pinking during opening. The most important advantage of it is to extend life time of mould parts.

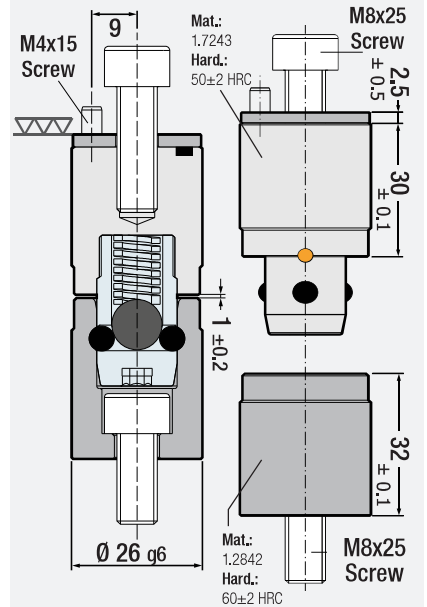

Order:
PR.263230

