

Pilot with Taper End Code: **SPK**

Standard Tolerances



When P = d1, shank / body tolerances apply.

Material: 1.3343 (M2) Hardness: 62 - 64 HRC

∅ d1	∅ d2	Taper ∅ P	N mm	Ref. P	L1 mm	L mm
10	13	4.85 ~ 10	8	5.6	Standard Alternative	71
13	16	6.30 ~ 13	10	7.1		
16	19	9.95 ~ 16	15	10.8	19	80
20	23	13.6 ~ 20	20	14.4		
25	28	17.3 ~ 25	25	18	25	100
32	35	20.9 ~ 32	30	21.7		
					25	125
					30	140



Order: **SPK**, d1 x P x L1 x L

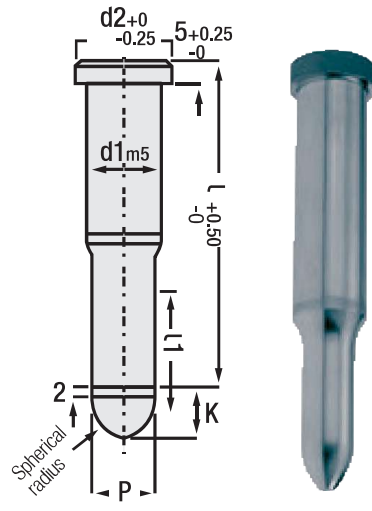

Pilot - Spherical Code: **SPX**

Standard Tolerances



When P = d1, shank / body tolerances apply.

∅ d1	∅ d2	K mm	Taper ∅ P	Standard L1	Alternative L1 min. max		L mm
4	7	4	1.55 ~ 4	8	10	-	50
5	8		1.55 ~ 5	13	10	-	60
6	9		1.55 ~ 6	13	10	-	71
8	11		2.45 ~ 8	19	13	-	80
10	13	10	3.15 ~ 10	19	13	25	80
13	16		4.95 ~ 13	19	13	25	
16	19		7.95 ~ 16	19	13	25	100
20	23		9.95 ~ 20	19	13	25	
25	28		11.95 ~ 25	19	13	25	
32	35		15.95 ~ 32	25	19	30	



Order: **SPX**, d1 x P x L1 x L



Order: **SPP**, d1 x P x L1 x L

Material: 1.3343 (M2)
Hardness: 62 - 64 HRC

Code: **SPX - SPP**

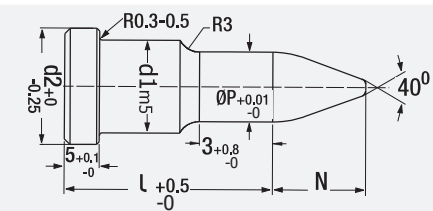

Pilot - Compact Type Code: **SMK**

d1	P	N	d2	L Length
4	1.95 ~ 3.99	4	7.0	20
5	2.65 ~ 4.99	5	8.0	22
6	3.30 ~ 5.99	6	9.0	25
8	4.10 ~ 7.99	7	11.0	28
10	4.80 ~ 9.99	8	13.0	35
13	6.25 ~ 12.99	10	16.0	
16	9.85 ~ 15.99	15	19.0	
20	13.50 ~ 19.99	20	23.0	
25	17.20 ~ 24.99	25	28.0	
32	20.80 ~ 31.99	30	35.0	

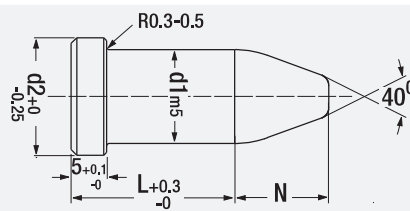

Pilot - Compact & Spherical Code: **SMX**

d1	N	d2	L Length
3.01 ~ 4.0	4	7	20
4.01 ~ 5.0	5	8	22
5.01 ~ 6.0	6	9	25
6.01 ~ 8.0	7	11	28
8.01 ~ 10	8	13	35
10.01 ~ 13	10	16	
13.01 ~ 16	15	19	
16.01 ~ 20	20	23	

Compact Pilots



Code: **SMK**

Pointed End



Code: **SMX**

Spherical End

Order: **SMK**, d1 x P x N x L

Order: **SMX**, d1 x N x L

Dies



Page

185