



## Screw Form Punch & Die Button Unit

Code: **VYZ**

Consists of 3 basic parts. **1-** Hss pierce punch **2-** Embossing die punch **3-** Die button.

In terms of working systematics; in all cutting and forming dies, it creates screw forms with the purpose of connecting two sheet metal strips. **Usage:** Hss pierce punch is brought to press operation by inserting in die button. While the embossing on the end of the die button bends and embosses, the hss pierce punch forms hole. The sheet metals are prepared to be screwed. The unit forms a hole in screw thread dimension tolerance and helical thread grooves with embossing for screwing and tightening (putting together).

**The unspecified tolerances will be according to DIN ISO 2768 T1 (f).**

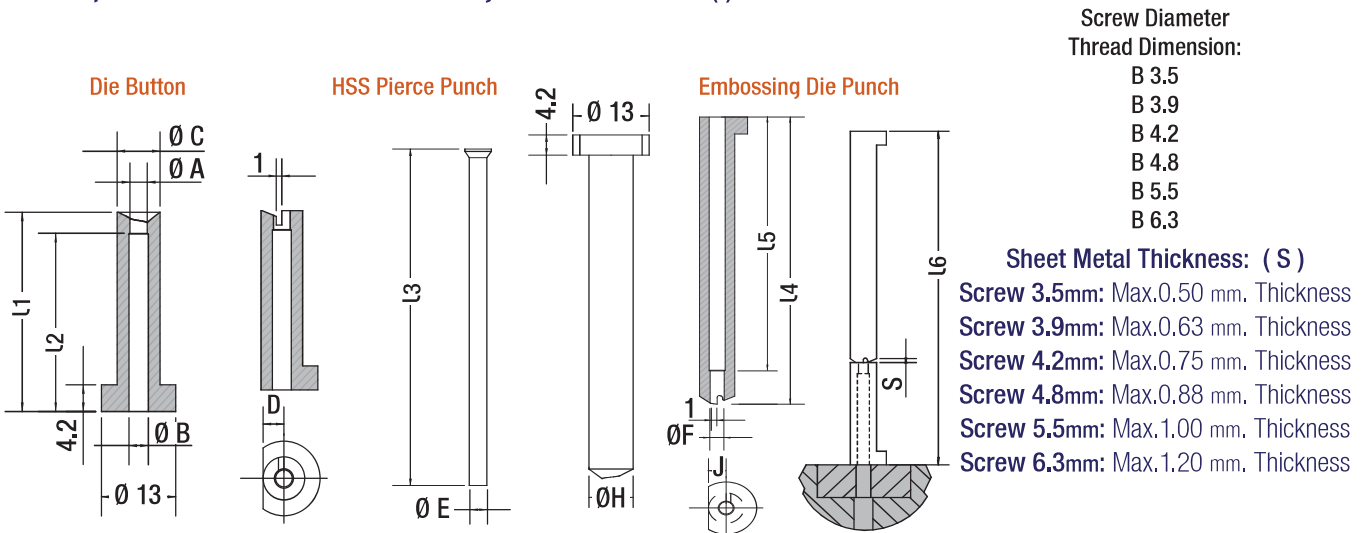

Ø Screw	A H7	B Ø -mm	C h6	D k6	E Ø -h6	F Ø -H7	H Ø -h6	J k6	L1 mm	L2 mm	L3 mm	L4 mm	L5 mm	L6 Length	S Sheet
B3.5	2.75	3.2	7.5	3.75	2.7	2.7	7.5	3.75	31.3	28	74.5	71.5	60	101.72	0.5
B3.9	3.05	3.4	7.5	3.75	3.0	3.0	7.5	3.75	31.3	28	74.5	71.5	60	101.85	0.63
B4.2	3.15	3.5	8.5	4.25	3.1	3.1	8.0	4.0	31.3	28	74.5	71.5	60	101.97	0.75
B4.8	3.85	4.2	9.0	4.50	3.8	3.8	8.0	4.0	31.3	28	74.5	71.5	60	102.10	0.88
B5.5	4.35	4.8	9.0	4.50	4.3	4.3	8.0	4.0	31.3	28	74.5	71.5	60	102.22	1.00
B6.3	4.85	5.3	10.5	5.25	4.8	4.8	10.0	5.0	31.3	28	74.5	71.5	60	102.42	1.20



**Order:**  
VYZ x Screw

